

USE BUELL RAMP
BUELL RAMPE BENUTZEN

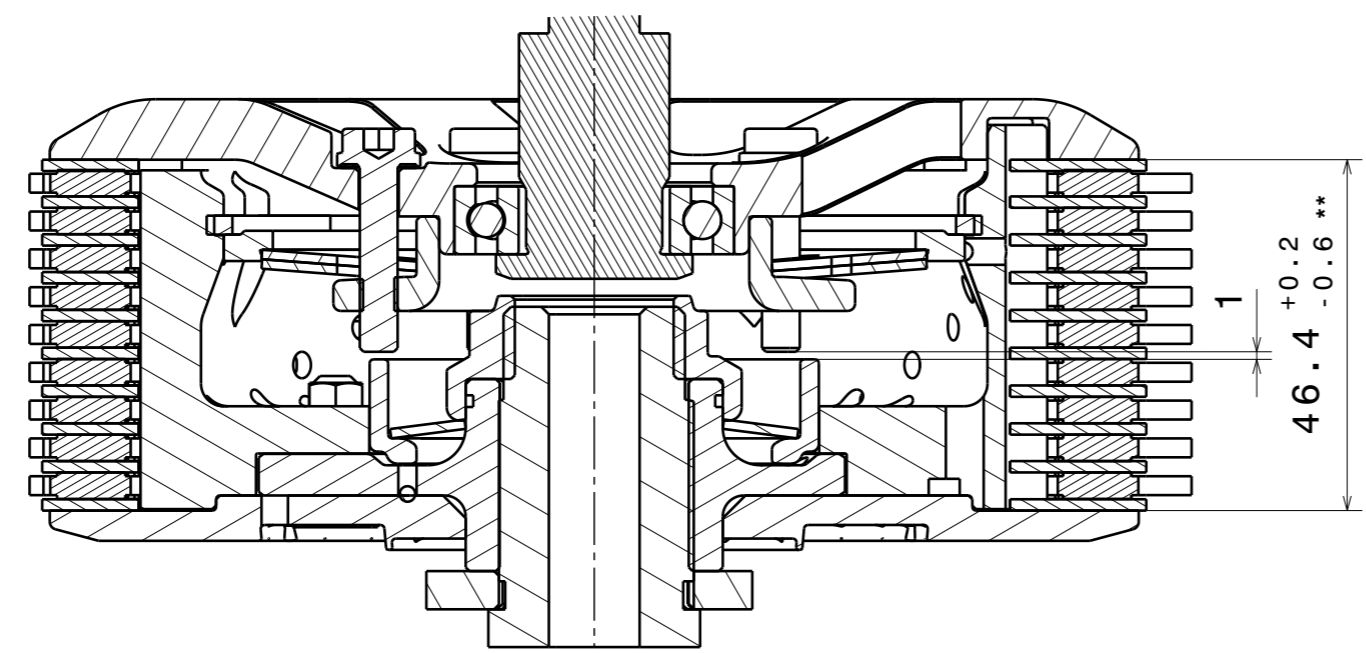

Das angegebene Belagspaketmass ist zwingend einzuhalten!
The plate package thickness must be strictly adhered to!

ITEMS LIST (604)			
ITEM	PART NAME	SRT NUMBER	QTY
1	BACK PLATE (BUELL RAMP)	004-37721	1
2	HUB CARRIER	004-07700	1
3	INNER HUB	004-37741	1
4	RELEASE RING	004-36975	1
5	KLAMP HUB 8MM	004-00518	1
6	PRESSURE PLATE	004-37941	1
7	DISK SPRING MAIN 47x88x 1000N	004-88100	2
8	TORQUE LIMITER SPRING X 950N	004-54095	1
8	TORQUE LIMITER SPRING 1 1100N	004-54110	1
8	TORQUE LIMITER SPRING 2 1300N	004-54130	1
9	BALL 8.0MM 60HRC	004-17801	5
10	COUNTERSUNK BOLT M6x20	004-17817	5
11	CIRCLIP 100mm HOLE SB100	004-17833	1
12	BOLT M5X24.5 HEXAGON SOCKET	004-05245	6
13	MAIN NUT M24x1.5 L=5.5	004-999241555	1
14	LOCKING RING 98	004-00698	1
15	NUT SELFLOCKING M6	999-12030605	5
16	BEARING 20x37x9	004-37910	1

GENERAL TOLERANCE				NOMENCLATURE:			
	DISTANCE	BORE Ø	SHAFT Ø	Buell 1125 Double spring			
0-10	±0.10	+0.1/-0	+0/-0.1	PART NUMBER: 004-37005-1 PART NAME:			
>10-30	±0.15	+0.2/-0	+0/-0.2	Suter Racing SCALE: 1:1 SIZE: A3 SHEET NR: 1/1			
>30-120	±0.20	+0.3/-0	+0/-0.3	SRT - Suter Racing Technology MATERIAL: See table WEIGHT: XXX			
>120-300	±0.30	+0.4/-0	+0/-0.4	DESIGNED BY: a.giussani DATE: 22.03.2011			
>300-600	±0.50	+0.5/-0	+0/-0.5	CHECKED BY: RS DATE: 22.03.2011			
				APPROVED BY: RS DATE: 22.03.2011			

This drawing is confidential. Copying or loan of this drawing or any information thereupon is prohibited without the written permission of Suter Racing Technology AG.