

004-23001-2 SuterCutch KAWASAKI:

KX 450F

06-16

KLX450R

08-11

KFX 450R (QUAD) 08-11

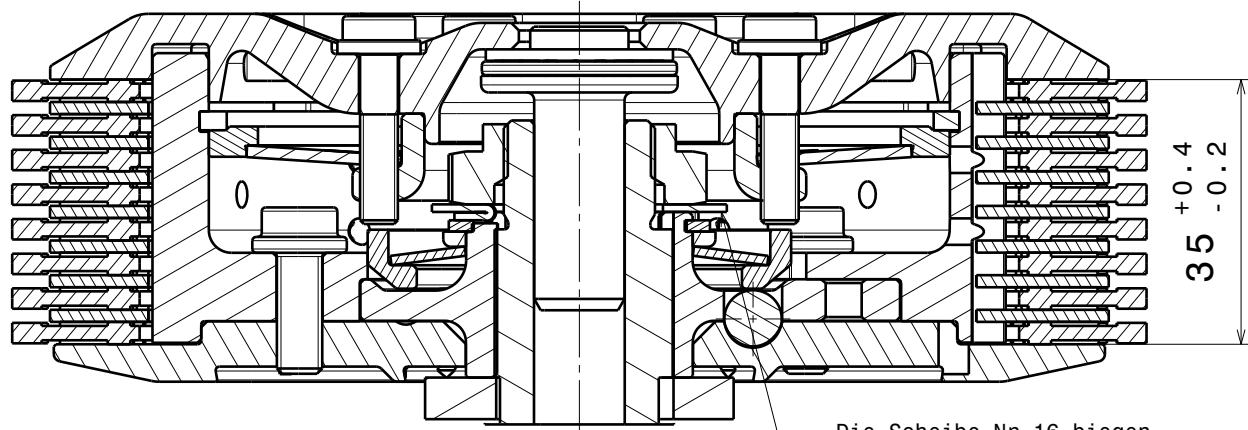
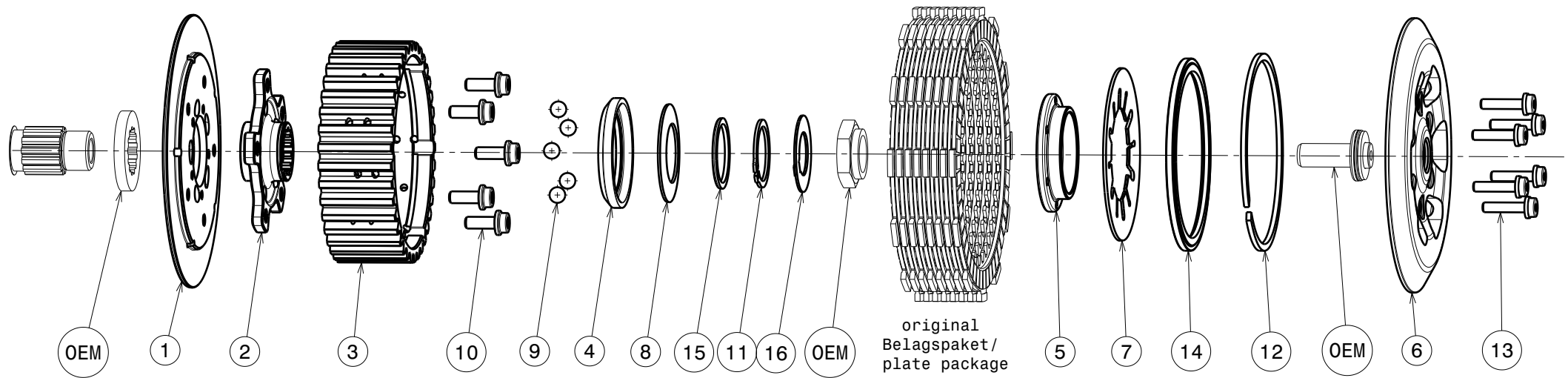

-Die Scheibe Nr.16 biegen um die Mutter zu sichern!
-Bend the washer No.16 to lock the nut!

Das angegebene Belagspaketmass ist zwingend einzuhalten!
The plate package thickness must be strictly adhered to!

ITEMS LIST (146)			
ITEM	PART NAME	SRT NUMBER	QTY
1	BACK PLATE 30°	004-23720	1
2	HUB CARRIER	004-18701	1
3	INNER HUB	004-23740	1
4	RELEASE RING	004-15975	1
5	KLAMP HUB 7.0mm	004-00507	1
6	PRESSURE PLATE	004-23940	1
7	DISK SPRING MAIN 47x88x1235N	004-88123	1
8	TORQUE LIMITER SPRING 1100N	004-50110	1
8.1	TORQUE LIMITER SPRING 750N	004-50075	1
8.2	TORQUE LIMITER SPRING 950N	004-50095	1
8.3	TORQUE LIMITER SPRING 1300N	004-50130	1
9	BALL 8.0MM	004-17801	5
10	SCREW M6x16	004-17816	5
11	CIRCLIP 30mm	004-00030	1
12	CIRCLIP 100mm	004-17833	1
13	DISTANCE SCREW M5x22.5	004-05225	6
14	LOCKING RING 98	004-00698	1
15	DISTANCE RING 30X36X1.6	004-997303616	1
16	LOCKING WASHER 22/39/1mm	004-07670	1