

# 004-21010-1 SuterClutch Honda CRF 450R 2019

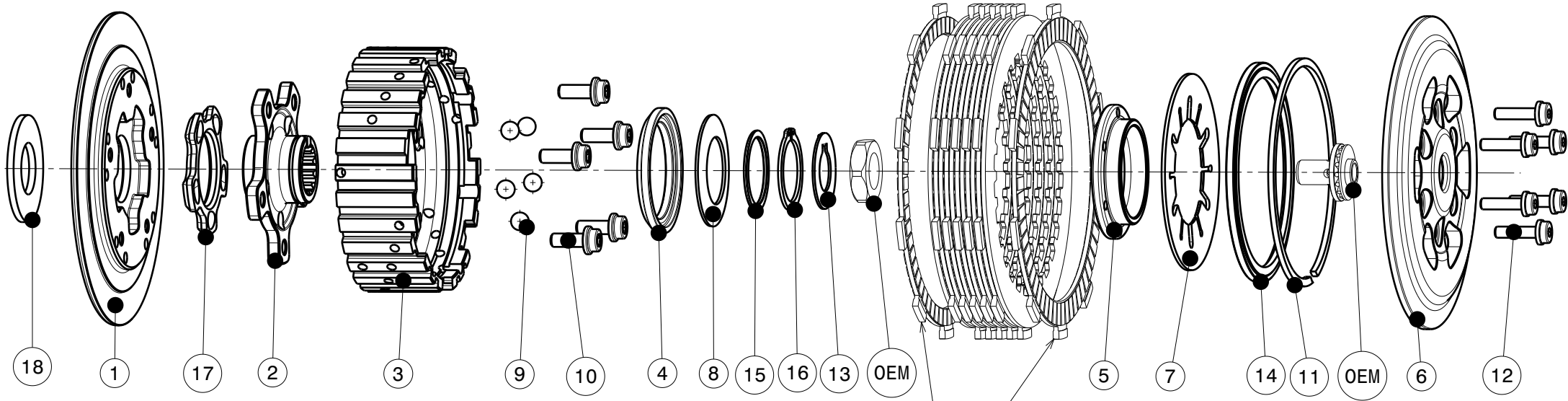

Achten Sie auf die korrekte Reihenfolge der ersten und letzten Reibscheibe, wie sie im originalen Handbuch beschrieben wird.  
Please note the correct order of the first and last friction disk as shown in the OEM manual.

**!!Bei falscher Reihenfolge wird erhöhter Verschleiss an Druck- und Grundplatte auftreten!!**  
**!!Assembled in wrong order will result in higher wear on the pressure- and backplate!!**

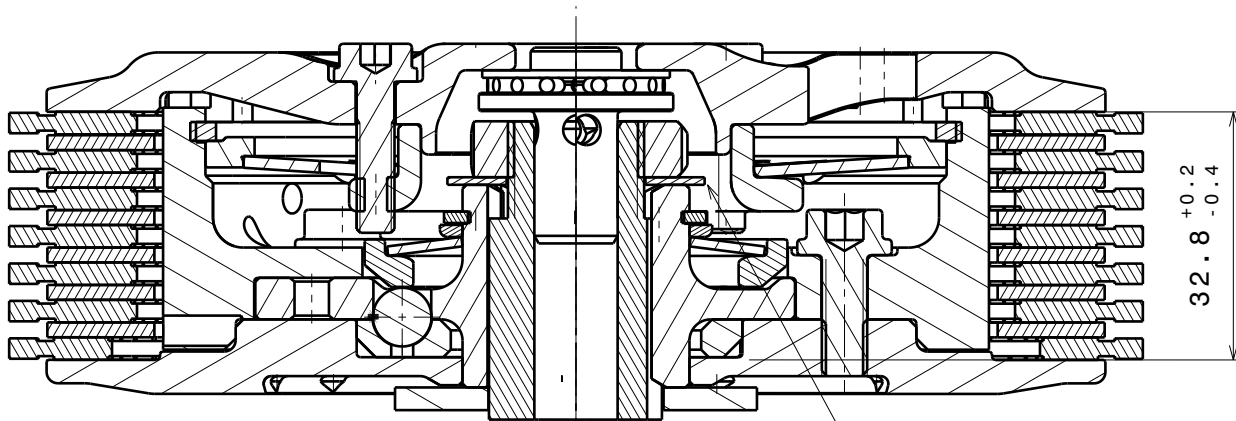

**Das angegebene Belagspaketmass ist zwingend einzuhalten!**  
**The plate package thickness must be strictly adhered to!**

-Die Scheibe Nr.13 biegen um die Mutter zu sichern!  
-Bend the washer No.13 to lock the nut!

Partlist: 2512

ITEM	PART NAME	SRT NUMBER	QTY
1	Back Plate	004-21722	1
2	Hub Carrier	004-21701	1
3	Inner Hub	004-08740	1
4	Release Ring	004-21976	1
5	Clamp Hub 7.0mm	004-00507	1
6	Pressure Plate	004-21946	1
7	Disk Spring Main 47x88x1310N	004-88131	1
	Torque Limiter Spring 950N	004-50095	1
8	Torque Limiter Spring 850N	004-50085	1
	Torque Limiter Spring 1100N	004-50110	1
9	Ball 8mm	004-17801	5
10	Bolt M6x16 Hexagon Socket	004-17816	5
11	Circlip 100mm Hole	004-17833	1
12	Distance Bolt M5x20.0	004-05200	6
13	Locking Washer 18/34/1mm	004-08670	1
14	Locking Ring 98	004-00698	1
15	Distance Ring 30x36x1.6	004-997303616	1
16	Circlip 30mm	004-00030	1
17	Ramp Insert 30°	004-00722	1
18	Thrust Washer 23x49x3.5	004-21990	1