

004-15008-6 SuterClutch Yamaha R1/M 15-18

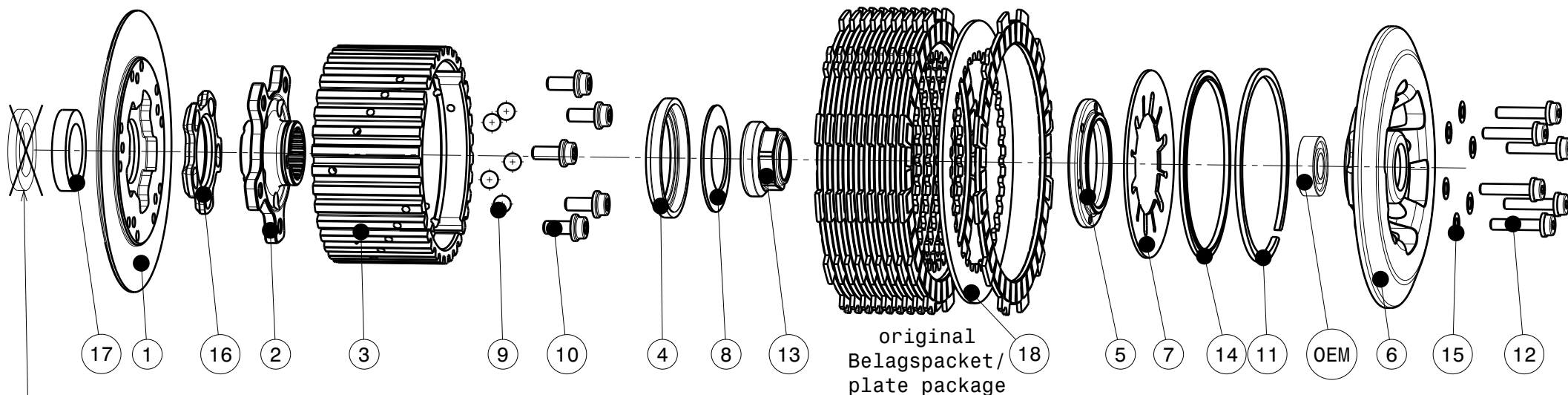

Die OEM-Scheibe nicht verwenden!
Don't use the OEM-washer!

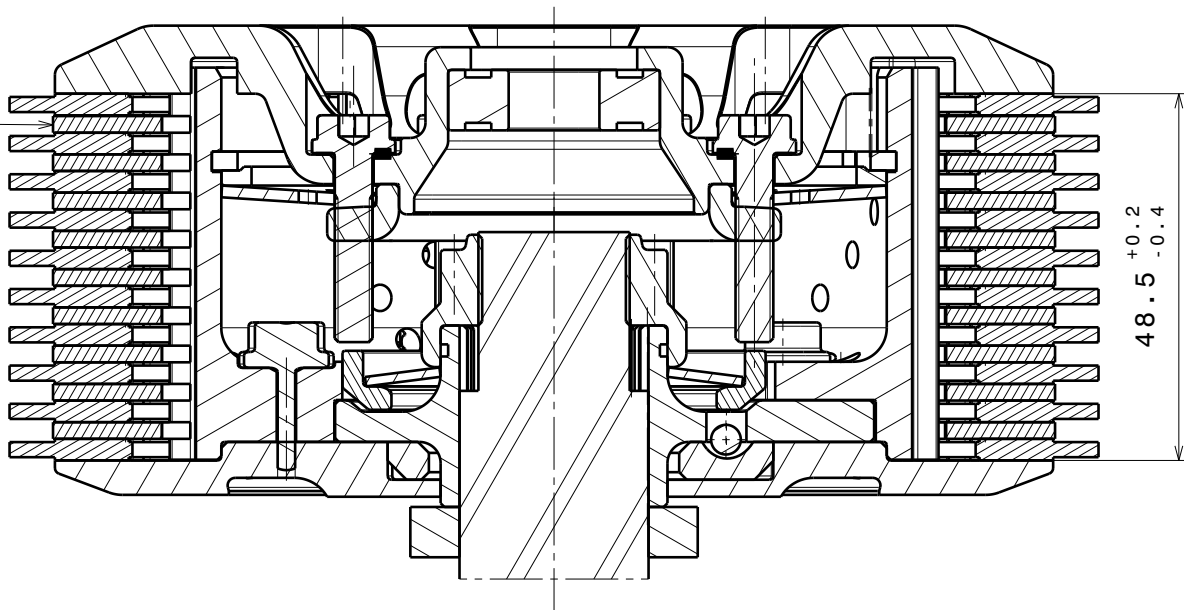

Diese Stahlscheibe muss durch die mitgelieferte (Pos.18) ersetzt werden
This steel disk has to be replaced with the delivered one (Pos.18)

Das angegebene Belagspaketmass ist zwingend einzuhalten!
The plate package thickness must be strictly adhered to!

ITEM LIST (1451)

ITEM	PART NAME	SRT NUMBER	QTY
1	BACK PLATE INSERT	004-15726	1
2	HUB CARRIER	004-15702	1
3	INNER HUB	004-15746	1
4	RELEASE RING	004-15975	1
5	KLAMP HUB 3mm	004-00503	1
6	PRESSURE PLATE	004-15948	1
7	MAIN SPRING 47x88x1600N	004-88160	1
8	TORQUE LIMITER SPRING 1300N	004-50130	1
8.1	TORQUE LIMITER SPRING 1500N	004-50150	1
8.2	TORQUE LIMITER SPRING 1100N	004-50110	1
9	BALL 8mm	004-17801	5
10	BOLT M6x14	004-17814	5
11	CIRCLIP 90mm	004-17804	1
12	DISTANCE BOLT M5x25.0	004-05250	6
13	MAIN NUT M20x1 L=5.5	004-999201055	1
14	LOCKING RING 88mm	004-00688	1
15	DISTANCE WASHER 0.2mm	004-00002	6
16	RAMP INSERT 32.5°	004-00723	1
17	THRUST WASHER R1 (7.0)	004-15952	1
18	STEEL DISK 2.6mm	004-15921	1