

# 004-15003-3 SuterClutch Yamaha R1 07-08

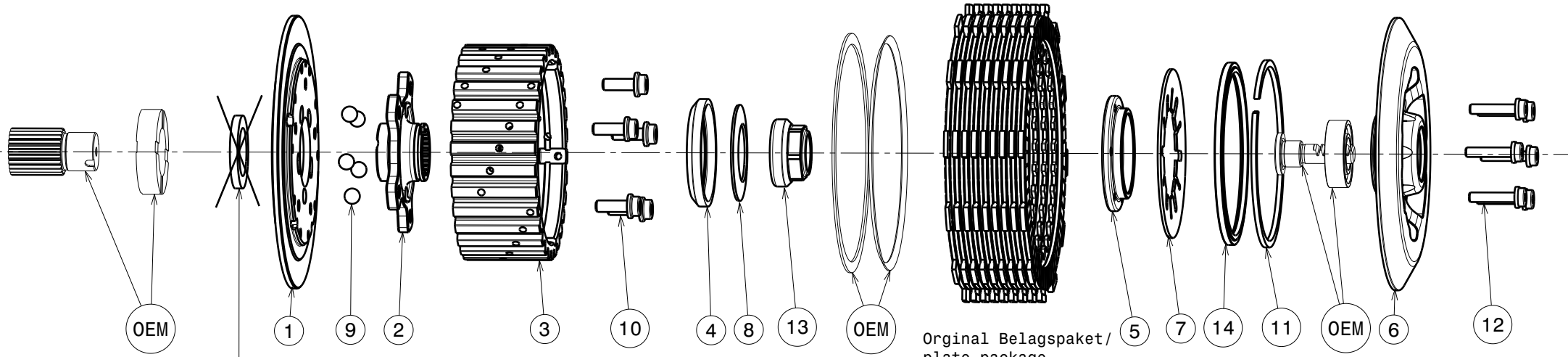

Scheibe nicht verwenden!  
don't use this washer!

Original Belagspaket/  
plate package

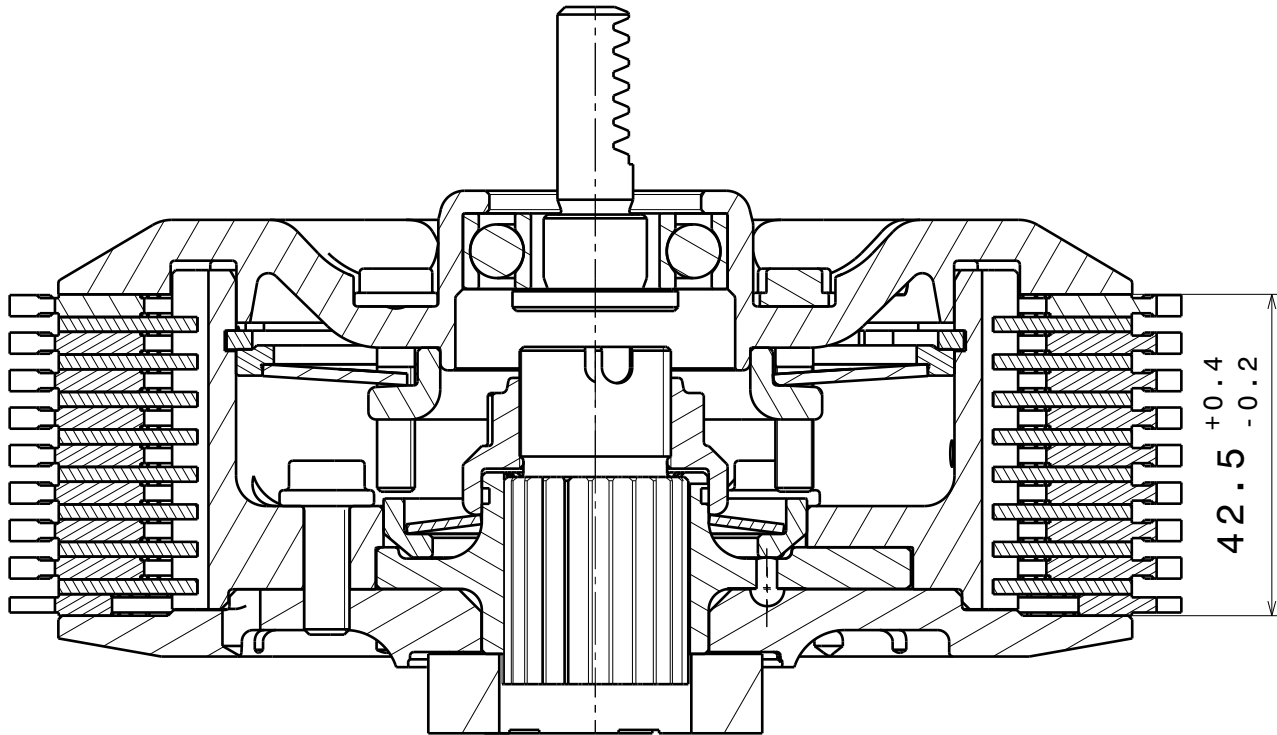

ITEMS LIST (247)			
ITEM	PART NAME	SRT NUMBER	QTY
1	BACK PLATE 35°	004-15722	1
2	HUB CARRIER	004-15702	1
3	INNER HUB	004-15740	1
4	RELEASE RING	004-15975	1
5	KLAMP HUB 5mm	004-00505	1
6	PRESSURE PLATE	004-15942	1
7	<b>DISK SPRING MAIN 88x47x1310N</b>	<b>004-88131</b>	<b>1</b>
8	<b>TORQUE LIMITER SPRING 1100N</b>	<b>004-50110</b>	<b>1</b>
8.1	TORQUE LIMITER SPRING 950N	004-50095	1
8.2	TORQUE LIMITER SPRING 1300N	004-50130	1
9	BALL 8.0MM	004-17801	5
10	SCREW M6x17	004-17802	5
11	CIRCLIP 95mm	004-17813	1
12	DISTANCE SCREW M5x24.5	004-05245	6
13	MAIN NUT M20x1 L=6.1	004-999201061	1
14	LOCKING RING 95	004-00695	1

**Das angegebene Belagspaketmass ist zwingend einzuhalten!**  
**The plate package thickness must be strictly adhered to!**